

TECHNICAL SPECIFICATIONS ROCKWHEEL G50

The Hydraulic Cutting Unit Rockwheel G50 can be supplied with either scaling/grinding or rock cutting drums.

Hydraulic Power	140 kW
Maximum Oil Flow	540,0 l/min
Optimum Oil Flow	360,0 l/min
Maximum Pressure	400 bar
Cutter Torque	37.504 Nm @ 350 bar
Pick Force	104,1 kN @ 350 bar
Drum Speed	53,0 rpm @ 360 l/min
Pick Speed	2,0 m/s @ 360 l/min
Operating Weight	2.458 kg
Excavator Size	42 - 52 t
No. of Picks	56 [38/30 mm Stepped Shank]

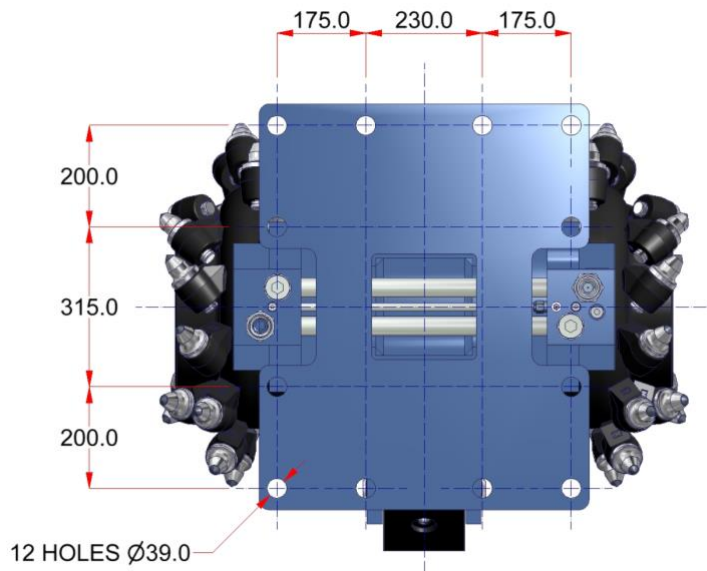

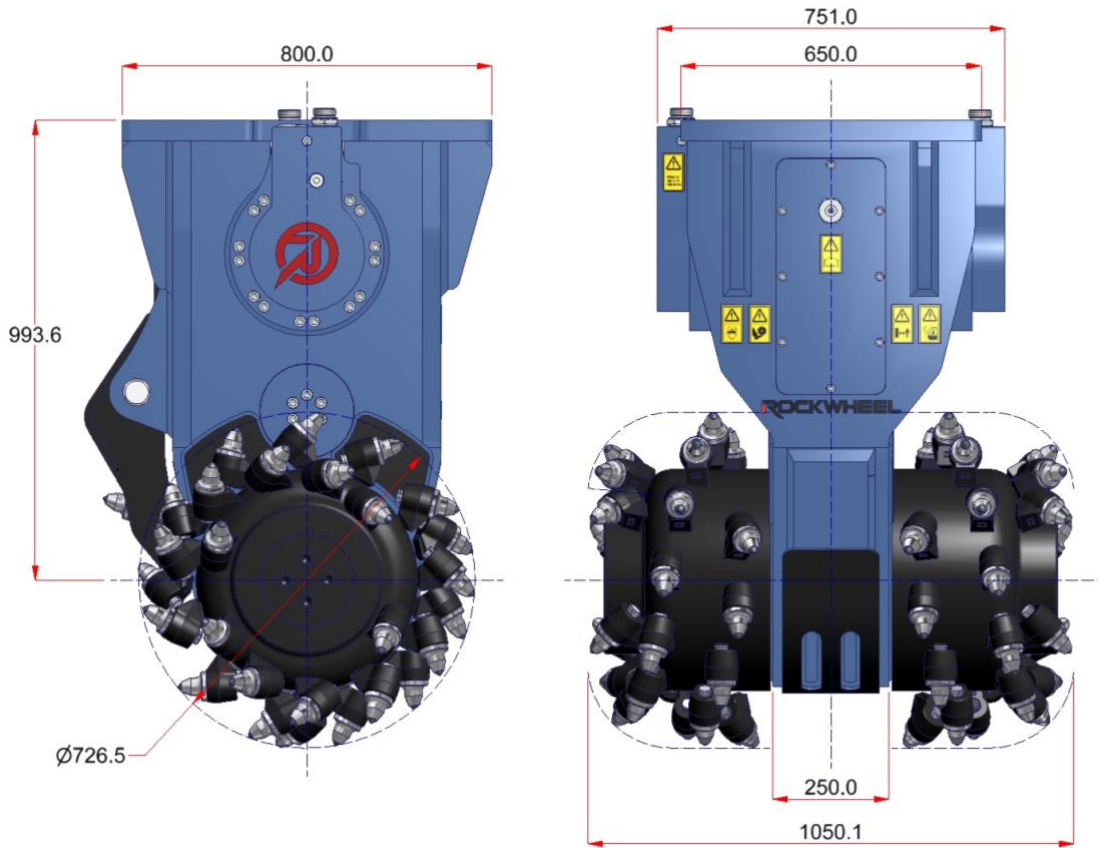

Rockwheel Cutting Units are designed and patented by Webster Technologies Ltd., UK.