

## TECHNICAL SPECIFICATIONS ROCKWHEEL G40

The Hydraulic Cutting Unit Rockwheel G40 can be supplied with either scaling/grinding or rock cutting drums.

Hydraulic Power	140 kW
Maximum Oil Flow	540,0 l/min
Optimum Oil Flow	360,0 l/min
Maximum Pressure	400 bar
Cutter Torque	40.629 Nm @ 350 bar
Pick Force	119 kN @ 350 bar
Drum Speed	49,6 rpm @ 360 l/min
Pick Speed	1,8 m/s @ 360 l/min
Operating Weight	1.662 kg
Excavator Size	30 - 50 t
No. of Picks	54 (38/30 mm Stepped Shank)

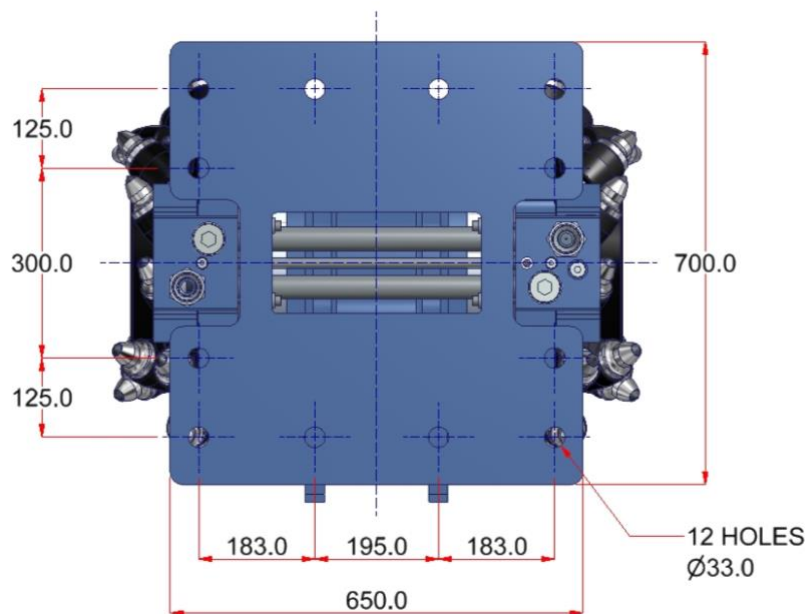

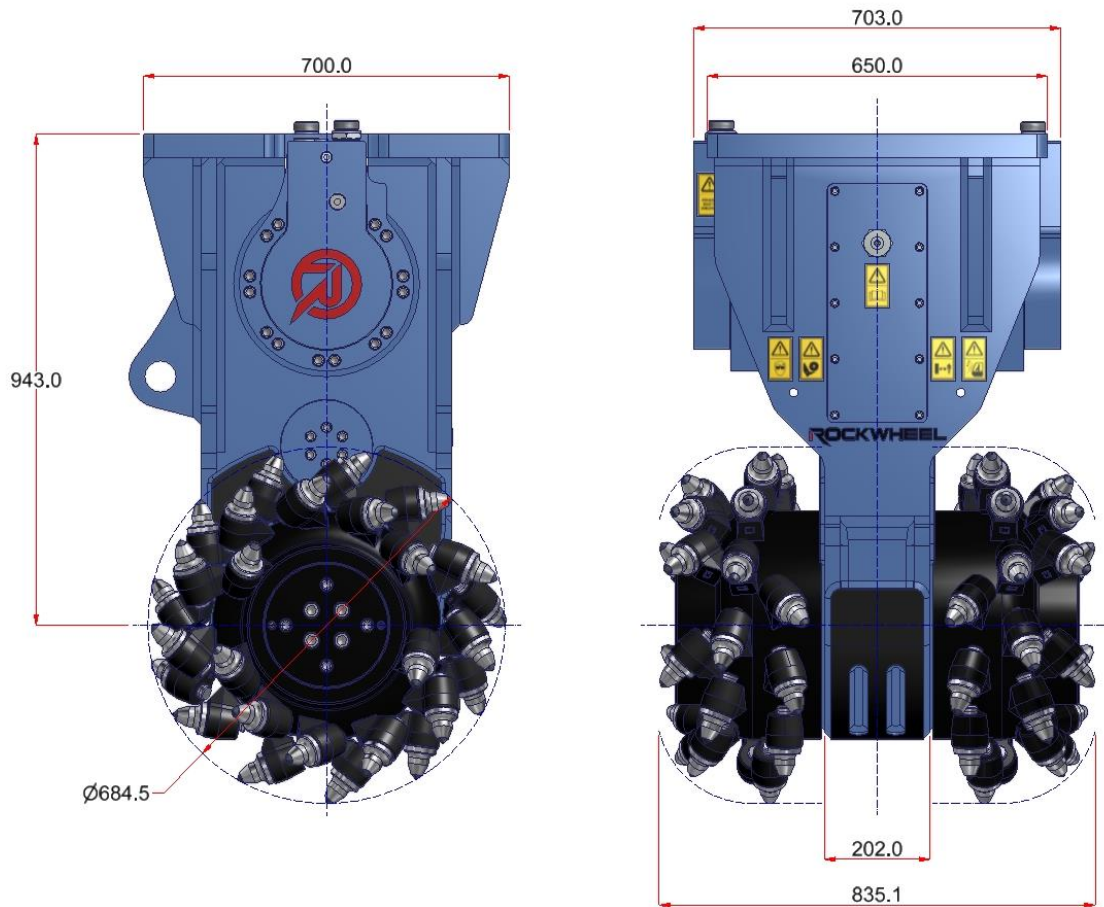

Rockwheel Cutting Units are designed and patented by Webster Technologies Ltd., UK.