

TECHNICAL SPECIFICATIONS ROCKWHEEL D10

The Hydraulic Cutting Unit Rockwheel D10 can be supplied with either scaling/grinding or rock cutting drums.

Hydraulic Power	29 kW
Maximum Oil Flow	112,5 l/min
Optimum Oil Flow	60,0 l/min
Maximum Pressure	400 bar
Cutter Torque	4.174 Nm @ 350 bar
Pick Force	19,8 kN @ 350 bar
Drum Speed	80,0 rpm @ 60 l/min
Pick Speed	1,8 m/s @ 60 l/min
Operating Weight	426 kg
Excavator Size	8 - 12 t
No. of Picks (Rock Drums)	56 [19,4 mm Shank]

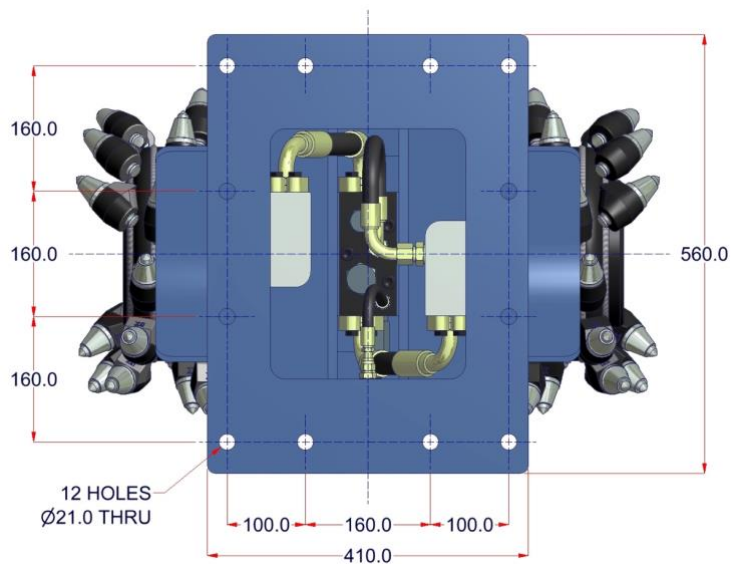

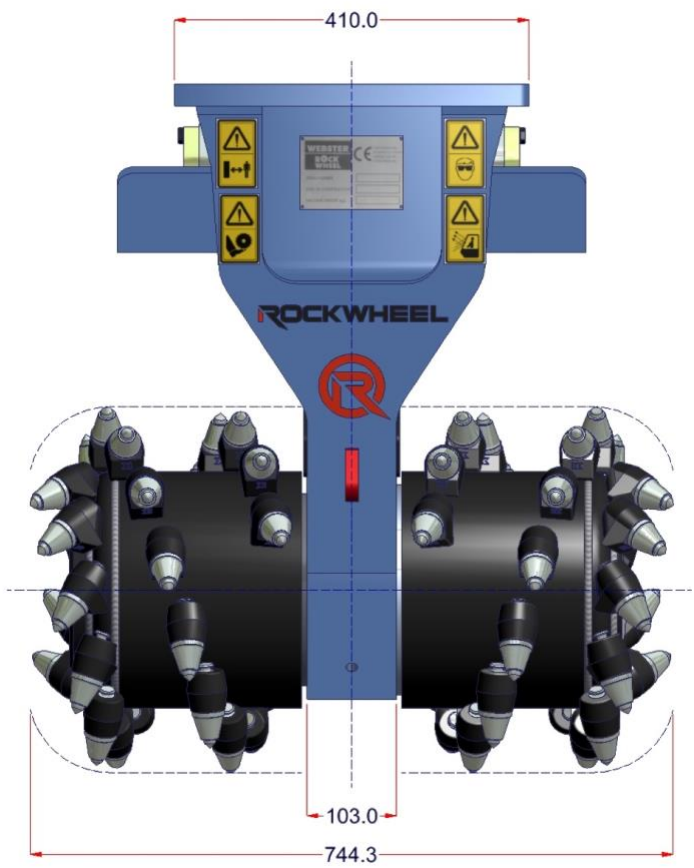
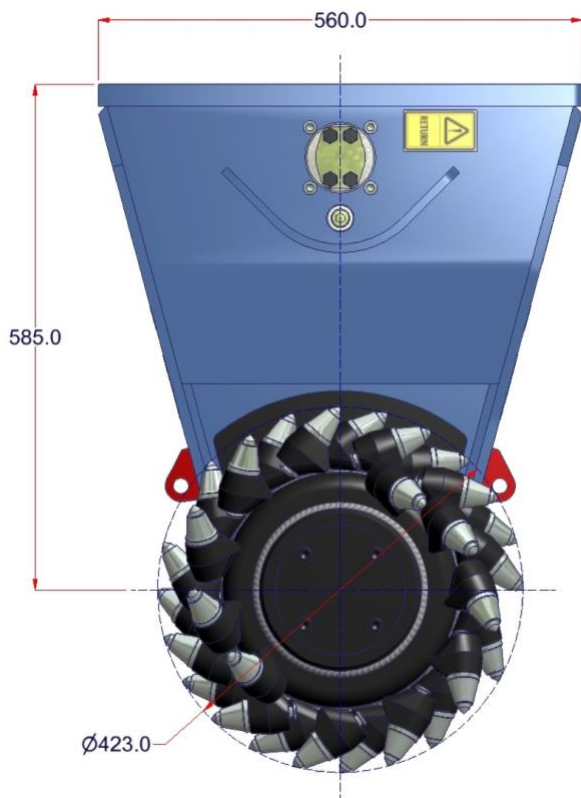

Rockwheel Cutting Units are designed and patented by Webster Technologies Ltd., UK.